

The Spare Tire

Palmetto A's of South Carolina

PO Box 8717

Columbia, South Carolina 29202

Model A Ford Club of America Chapter

Model A Restorers Club Region

Model A Ford Foundation, Inc.

Website: www.palmettoas.net

Facebook: [Palmetto A's of SC](https://www.facebook.com/PalmettoAsOfSC)

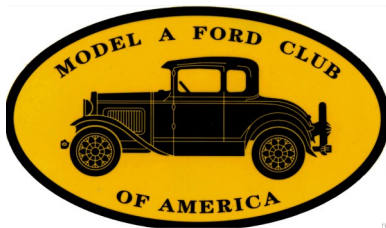

BOSTON EVENING TRANSCRIPT, THURSDAY, DECEMBER 11, 1927

FIVE

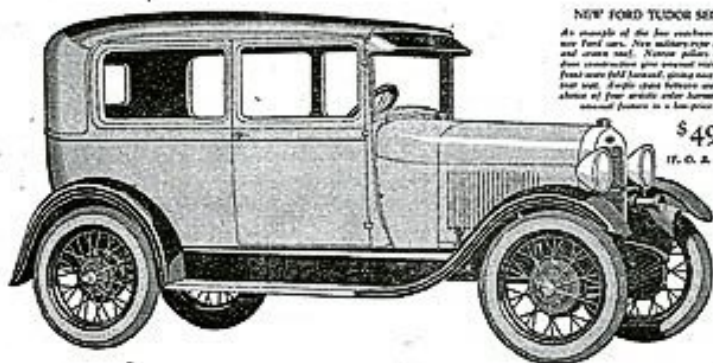

NEW FORD TUDOR SEDAN
An example of the low overhanging of the new Ford cars. New military-type one door and crown roof. Narrow pillars and top floor construction give unusual room. Roof floor runs half forward giving more space to rear seat. Double chain between seats. Four doors of four wheels and four wheels. Your choice of four colors. *(F. O. A. Detroit)*

\$495

First Pictures of the New Ford Car

Get complete details

TOMORROW at Ford salesrooms

FOR SEVERAL years we have been working on the new Ford car. For weeks and months you have been hearing rumors about it. For the past few days you have been reading some of the details of it in the newspapers.

Whatever you do tomorrow, take at least fifteen minutes to get the full story of this new automobile.

You will realize then that it is an entirely new and different Ford car, designed and created to meet modern conditions—a car that brings you more beauty, speed, quiet, comfort, safety, economy and stamina than you ever thought possible in a low-price car.

Automobile history will be made tomorrow, for the new Ford is not only new in appearance and performance . . . it is new in mechanical design. Many features of it are exclusive Ford developments. Some are wholly new in automobile practice. Its low price is a reflection of manufacturing improvements and economies that are as epoch-making as the car itself.

Nineteen years of experience in building 15,000,000 automobiles are behind the new Ford car and have counted in its making. Resources unmatched in the motor car industry are its heritage and its birthright.

The Ford policy of owning the source of raw materials, of making virtually every part, of doing business at a small profit per car, has cut many dollars off the price you would ordinarily have to pay for a car like this.

So we say to you—learn about this new Ford car tomorrow. Compare it with any other car in the light-car field for beauty of line—for comfort—for speed

—for quick acceleration—for flexibility in traffic . . . for steadiness at all speeds . . . for power on the hills . . . for economy and low cost of up-keep . . . for its sturdy ability to stand up under countless thousands of miles of service.

Then you will know why tomorrow will be remembered as one of the greatest days in the entire history of the automobile industry. . . . Then you will know why the new Ford car will be *your* car.

NOTE THESE FEATURES

- Beautiful new low body lines*
- Choice of four colors*
- 55 to 65 miles an hour*
- Remarkable acceleration*
- 40 horse-power*
- Four-wheel brakes*
- Standard, selective gear shift*
- Hydraulic shock absorbers*
- 20 to 30 miles per gallon of gasoline*
- Theft-proof coincidental lock*
- Typical Ford economy and reliability*

STANDARD EQUIPMENT ON ALL NEW FORD CARS

- | | |
|-------------------------|---------------------------------|
| Seater | Dashlight |
| Five steel-spoke wheels | Mirror |
| Windshield wiper | Rear and stop light |
| Speedometer | Oil gauge |
| Gasoline gauge | Tools |
| | Pressure grease gun lubrication |

NEW FORD SEDAN

A big roomy car. Wide with generous legroom front and rear. Four convenient doors. Unusually large windows. Rich upholstery and full-sized dashboard. Four lights. Your choice of four colors. *(F. O. A. Detroit)*

\$570



NEW FORD ROADSTER

A big, low, roomy car. As low as a truck. Wide doors. Deep windows. Rich upholstery. Full-sized dashboard. Double seat. Your choice of four beautiful color combinations. *(F. O. A. Detroit)*

\$385



NEW FORD COUPE

There is a lot of the business done in the country and across the new Ford Coupe. Handy package shelf in back of seat and unusually large extra front luggage space in rear trunk. Your choice of four beautiful colors. *(F. O. A. Detroit)*

\$495

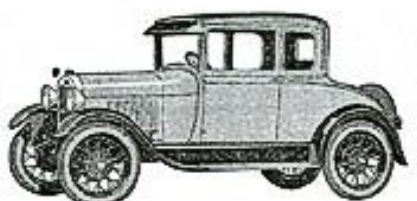

NEW FORD SPOT COUPE

Combines the great enjoyment of the roadster and the advantages of a hard top. Handy and standard. Luggage space in rear trunk. Your choice of four beautiful colors. *(F. O. A. Detroit)*

\$550



NEW FORD DELAYON

Another big, low, roomy car. All four doors open for load. Luggage space and deep seat. Side windows have unusually large windows. Your choice of four colors. *(F. O. A. Detroit)*

\$395



FORD MOTOR COMPANY
Detroit, Michigan

“A” Note from the President...

Our December Christmas party club meeting/tour was to Prosperity, SC. It was a cold but still a nice day in December to enjoy our ride in our “A’s.” Again, I want to, on behalf of the club, offer thanks to Sherry and Tom Mack for inviting us to their “Vintage Car Show Room” and hosting our end of year party. We enjoyed fellowship and a wonderful catered lunch. We continue to pray for those who were not able to gather with us for this event due to illness and other medical situations. We pray for their recovery and look forward to seeing them in the coming year.

January 21st brings the start of a new year of Model A fun with breakfast at 8 AM at the Lizards Thicket restaurant, downtown Columbia on Elmwood Avenue. After breakfast, for those who have made the “reservation/signup” with Happy Begg, we will begin our two day/overnight “Mystery Tour.” The signup was required as reservations had to be made for hotel accommodations for the overnight trip. I know many are excited to see where this adventure will take us! Please be gassed up and ready to travel. Don’t forget to charge and bring your walkie talkies. (You might want to bring the charger to recharge for day two.)

As was done last year we will hold our annual business/budget meeting in February.

I look forward to starting this New Year of “Model A’ing” with you all. Remember, if your “A” is the “repair or restore shop,” you can still be a part of the fellowship in your “modern”. **So, let’s dust’um off, gas’em up, and let’s go “Model A’ing!”**

John Cockerill



FRONT COVER: Ad for the new Model A Ford Line from the December 1, 1927 *Boston Evening Transcript*. This Boston MA newspaper was published from July 24, 1830 to April 30, 1941.

Board of Directors

- President* - [John Cockerill](#) (803)446-3837
- Vice President* - [Happy Begg](#) (803)622-0048
- Secretary* - [Debbie Areheart](#) (803)960-6497
- Treasurer* - [Dick Fraser](#) (803)622-7582
- Newsletter Editor* - [Twila Cockerill](#) (803)446-5803
- Membership Director - [Cheryl Austin](#) (803)351-5687
- Past President - [Happy Begg](#) (803)622-0048
- National Director* - [Wayne and Debbie Areheart](#) (803)960-0927
- Members At Large - [Bruce Edge](#) (803)206-4207
- [Dan Ward](#) - (864)415-5496

*Denotes Officer of the Club

Committee Chairs

- Tour Director - [Cheryl and Danny Austin](#) (803)351-5687
- Technical Director [Wayne Areheart](#) (803)960-0927
- Librarian - [Davin Smith](#) (803)822-4141
- Sunshine - We need a volunteer!
- Palmetto A’s Annual Picnic - Committee
- Swap Meet - Committee
- Christmas Party - Committee
- Fundraising - [Dick Fraser](#)
- Community Outreach - [John Begg](#)
- Webmaster - [Happy Begg](#)
- Website: www.palmettoas.net

Editor’s Note.....

Happy New Year!
 And yes, I’m still here!
 It has been so cold that it’s hard to believe we are going to actually get in our Model A’s and go for a road trip on the 21st! Model A’ers are brave people!
 By now you will have noticed that I have made changes in this newsletter. When things get boring and predictable, it is time for a change. From now on, ALL meeting and event information will be on the third page. That means you will have to turn the pages and look at more than just the cover. You all would be surprised at the number of people that have admitted that they do not read the newsletter. They just look for the next meeting date, time, and place. There were times when that info was in the president’s letter, and I did not repeat it in a separate box and your president got calls and emails asking for the ‘missing’ information which let him know that some members did not read his letter. Redundancy is on my chopping block!
 I have great hopes that 2023 will be a much better year than the past two years and that our Model A family will grow and prosper.
 See you at breakfast on the 21st!

Twila





Down the Road

Is there a destination to which you would like to drive your Model A? Is there a lunch spot to which you would like to drive your Model A? Call or email Cheryl and Danny Austin at 803-351-5687, daustino02@sc.rr.com. They are looking for your ideas and input!

Palmetto A's Schedule for 2023

January 21 - 8:00 am Breakfast at Lizard's Thicket, 818 Elmwood Avenue. Those who have signed up for the Mystery Tour will leave from here around 9:30.

February 18 - Annual Budget Meeting with Chicken Bog at the Austin's

March - Palmetto A's Annual Picnic

PLEASE NOTE: DATES AND PLACES ARE SUBJECT TO CHANGE!

Other Events of Interest

2023

April 14-15 - Old 96 17th Annual All Model A & Model T Parts Swap Meet

April 14-16 - [MARC Membership Meet](#) in Bay City, Michigan

July 16-21 - [MAFCA National Tour "Backroads to the Classics" in Indiana/ Michigan hosted by Southeastern Tour Group](#)

September 15-16 - 12th Annual Model A Days at the MAFFI Museum in Hickory Corners MI

September 16 - International Model A Day

2024

June 23-29 - MAFCA National Model A Convention in Ruidoso, NM hosted by the Southwest Model A's

Room Release date is June 15th, 2022



Reservation information will be released on June 15th, 2022, & posted on social media



All pertinent information, phone, code & room cost will be announced at the MARC National

JOIN US IN BAY CITY, MI FOR THE

MARC Membership Meet

April 14-16, 2023

Hilton Double Tree Riverfront • Bay City, Michigan

Hosted By



2023 MAFCA National Tour

"Backroads to the Classics"

July 16-21, 2023

Hosted by Southeastern Touring Group

<https://www.southeasterntouringgroup.com/2023-mafca-national-tour>

The Spare Tire

Due date for submissions for the February 2023 issue is January 20th



HOLIDAY GATHERING, TOM MACK'S SHOWROOM
 10 DECEMBER, 2022
 PHOTOS CURTESY OF TOM MACK

January Birthdays

Alinia Smith - 4th

Bobby Williamson - 7th

Karen Lewter - 9th

Tom Mack - 13th

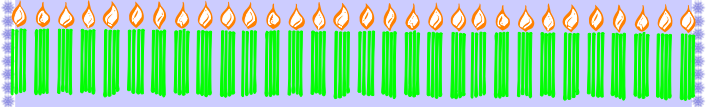

Sunshine Report

Please keep the following folks in your thoughts and prayers: Richard Buff, Mac & Mary Day, Wes Porterfield, and JP Temple.

Remember: call, write or send a card to someone who needs encouragement. We are "FAMILY" and it helps to be thought of and prayed about.

If you have any Sunshine concerns, please call or email the newsletter editor to add the name to our Sunshine Report.

Dues!

Your annual dues must be paid by January 31. No dues, no newsletter! And, if your dues are late, your name will not be included in the roster that must be sent to the national clubs in February.

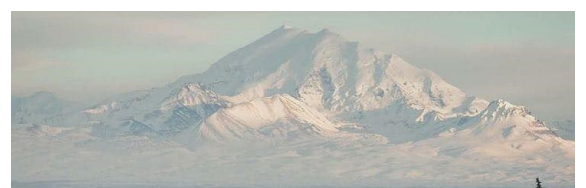

Treasurer's Report, December, 2022

We continue to maintain a balance in line with the club budget as set and approved by the Board of Directors. All bills and receipts are processed promptly. The checkbook is balanced monthly with no discrepancies. The club account balance is reported at each General Membership meeting.

Dick Fraser, Treasurer

Rear Brake Drums

by Tom Endy

The hubs on the rear brake drums of a Model A Ford are found in three different configurations. The Judging Standards are silent concerning which configuration should be installed on a given year/month of production car. The reason is probably because the hubs cannot be seen during judging.

The Ford Service Bulletins describes the three configurations but do not reference specific year/month of installations. See the service bulletin below (page 377 for September 1929, page 147 in the book). The only year/month reference useful to the modern Model A enthusiast is that the grooved design hub only will be supplied after September 1929.

The machining design on the shoulder shank of the three hubs was intended to allow some type of pulling tool to be attached in order to pull the drum off of the tapered axle shaft.

The Mitchell Overdrive Company makes an excellent tool that can be configured to accommodate all three designs. It is small and compact and is easily carried in the car with other common hand tools.



The Mitchell rear brake drum pulling tool: The two C-shaped parts (painted green on the left) are used to configure the tool to pull the shoulder and tapered design hubs. The two C-shaped parts (painted black on the right) are used to configure the tool to pull the grooved designed hubs.

DIFFERENCE IN HUBS

Three different types of hubs have been used with the A-1115-B rear hub and brake drum assembly. See Fig. 765.

The "shoulder shank" design is distinguished by a shoulder located midway on the shank.

The taper shank type is practically the same as the shoulder shank design except that the shank is tapered from the shoulder to the outer end.

The grooved shank design is distinguished by a groove located midway on the shank.

These hubs are all interchangeable. However in so far as stocks permit dealers should use the same design hub on both wheels. In the future only the grooved design hub will be supplied.

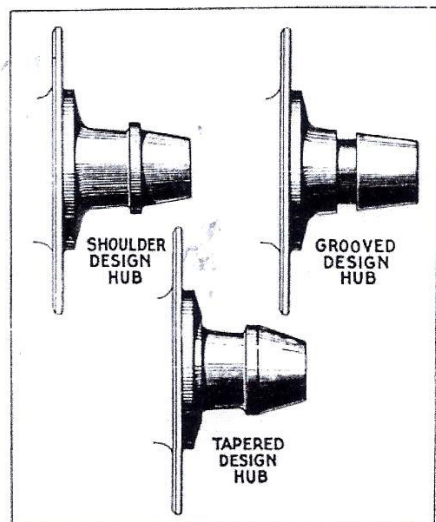

The Mitchell Mfg Co
 1157 Parker St.
 Colusa, Ca 95932
 530-458-4500
 1-800-859-2088

Santa Anita A's Member, Tom Endy; Editor of the Victoria Association Newsletter (The Bustle) for the past 20 years, has created the 20+ years of the work. Some of the articles and documents have been featured in the MAFCA Restorer Magazine, other club's websites, and some are not published anywhere but here: santaanitaas.org/tom-endys-tech-articles/. Enjoy, utilize, and learn!

The Ford Service Bulletin for Sept. 1929

Model A Ford Technical Questions?

Paul Shinn has gathered a group help answer your technical questions about Model A's. The group includes MAFCA's current tech director and several past tech directors. You can email your questions and concerns to: ModelATechQuestions@gmail.com

Who knows, you may even see your question answered in *The Restorer!*

DID YOU KNOW?

The MAFCA website has a list of Tech videos. Check them out here:

<https://www.mafca.com/videos.html#technical>



NEED HELP WITH YOUR MODEL A?

IS YOUR PROBLEM SOMETHING THAT COULD BE ADDRESSED BY THE CLUB "TECH TEAM?" WAYNE AREHEART AND THE "TECH TEAM" ARE LOOKING FOR SMALL JOBS THAT WOULD PROVIDE A "LEARNING" TECH SITUATION FOR THE CLUB. FOR MORE INFORMATION, PLEASE CONTACT WAYNE AT dareheart@sc.rr.com or JOHN COCKERILL AT johntwllac@yahoo.com.

WOMEN'S Smart Dresses

Broadcloth
24 N A663
\$4.98

Women's sizes 24 to 44 inches bust. State Bust measure.
24 N A663 Navy Blue (as illustrated)
24 N A664 Rust Brown
24 N A665 Gracklehead Blue
O.U.B. PRICE, Each..... \$4.98 Postage, 12c Extra

Embroidery always lends a rich touch to a dress, but this of All Silk Flat Crepe truly has one of the most realistic designs we have ever seen. The blouse of this over-glove dress is like a field of flowers and what worked in silk hose. The skirt front is smartly pleated. The hem in the front is of self material. Sizes 24 to 28 are about 44 inches long; 40 to 44, about 50 inches long.
Women's Sizes: 24 to 44 inches Bust. State Bust measure.
24 N A672 Gracklehead Blue (as illus.)
24 N A673 Palmetto Green
24 N A674 Rose Haze
O.U.B. PRICE, Each..... \$8.98 Postage, 12c Extra

ALL SILK Charmeuse
24 N A666
\$5.98

This fashionable Dress of All Silk Charmeuse has V-neck and is trimmed with very smart lace insertion, and lined with a self material. Note how pretty the fine glass buttons like the contrasting color silk jacket. The finely pleated skirt has a narrow string belt. Size 24 to 28 are about 44 inches long; 40 to 44, about 48 inches long.
Women's Sizes: 24 to 44 inches Bust. State Bust measure.
24 N A666 Navy Blue
24 N A668 Black
O.U.B. PRICE, Each..... \$5.98 Postage, 12c Extra

ALL SILK Flat Crepe
24 N A669
\$7.98

This dress is fashioned of great quality All Silk Flat Crepe with self silk embroidered silk insertion on the round V-neck and down the entire length of the sleeve. The tucked band across the front is finished with tabs and covered silk buttons of contrasting color. There is a bow of self material and jeweled trim at shoulder. Sizes 24 to 28 are about 44 inches long; 40 to 44, about 50 inches long.
Women's Sizes: 24 to 44 inches Bust. State Bust measure.
24 N A669 Cedarwood Brown (as illustrated)
24 N A670 Gracklehead Blue
24 N A671 Claret Red
O.U.B. PRICE, Each..... \$7.98 Postage, 12c Extra

Women's Sizes 34 to 44 Bust

ALL SILK Flat Crepe
24 N A672
\$8.98

ALL SILK Charmeuse
24 N A675
\$9.98

ALL SILK Flat Crepe
24 N A674
\$7.98

46 For Quality, Style And Economy, Buy in New York, The Merchandise Center Of The World Charles William Stores, Inc. New York City

Cook's Corner.....

Impossible Buttermilk Pie

- 1½ cups sugar
- 1 cup buttermilk
- ½ cup biscuit mix
- ⅓ cup melted butter
- 1 teaspoon vanilla
- 3 eggs

Preheat oven to 350°.

Grease a 9" deep dish pie pan.

Mix all ingredients until smooth, about 30 seconds in a blender or one minute with a hand mixer. Pour into pie pan. Bake about 30 minutes or until a knife inserted in the center comes out clean.

Mama Gerry's Party Potatoes

- 8-10 medium sized potatoes, peeled and cubed
- 8 ounces cream cheese
- ¼ cup sour cream
- 1 teaspoon dry onion soup mix
- 2 tablespoons melted butter
- milk
- salt
- paprika

Preheat oven to 325°.

Cook potatoes in water until fork tender, drain.

Mix cream cheese and sour cream and add to potatoes. Beat until fluffy, adding a little milk if necessary. You want them to be a bit stiff. Add salt to taste and dry onion soup mix. Spoon into greased casserole. Brush top with melted butter and sprinkle with paprika. Bake for 20 minutes.

"QUALITY FIRST" IS OUR MOTTO

F \$1.69

Leather Lined

G \$1.98

Angora Lined

H \$3.95

J \$2.25

Mittens

The Season's Latest Styles

K \$2.98

All Wool

L \$1.00

M \$1.69

N \$1.00

P \$9.95

All Wool

See Opposite Page for Descriptions For "How to Measure" See Opposite Page

326 SEARS, ROEBUCK AND CO.



A World Magazine

A MAFCA Publication

Have you downloaded the most recent edition of A World Magazine? Click on the link, download the magazine and print! This is a great magazine with fun for all ages!

<http://www.mafca.com/downloads/Youth/A-World.pdf>



CLICK HERE FOR MAFFI APPLICATION

<https://www.maffi.org/WSContent/Download/membershipapp2022.pdf>

The Palmetto A's is a not for profit organization with chapter affiliations with MAFCA and MARC. The organization is dedicated to the preservation and the restoration of the Model A Ford automobile and supports membership in the national organizations dedicated to the same purpose. Palmetto A's is one of the oldest Model A Clubs in the nation, having been active for over 61 years. Monthly meetings are generally held the third Saturday of the month, time and location announced in **The Spare Tire**, the club's monthly newsletter. Palmetto A's membership dues are \$25 per year.

Members are encouraged to join the following national clubs:

Model A Ford Club of America.

Annual dues are \$50 and include a subscription to **The Restorer Magazine** from MAFCA, 250 South Cypress St., La Habra, CA 90631 and

Model 'A' Restorers Club

Annual dues are \$50 and include a subscription to the **Model 'A' News Magazine** from MARC, 6721 Merriman Road, Garden City, MI 48135



[CLICK HERE FOR MAFCA](#)

[MEMBERSHIP APPLICATION](#)



[CLICK HERE FOR MARC](#)

Benefits of National Club Memberships

Membership in MAFCA includes the following:

A one year subscription to The Restorer, our award-winning bi-monthly magazine including free classified ads.

The right to register and participate in all National and Regional MAFCA meets

Voting privileges in National elections of officers and by-laws revisions

Free classified advertising on the MAFCA web site and posting of photo of your car in the Photo Album section

Technical advice to help restore your Model A and keep it in top shape

National MARC Membership Includes:

Six issues each calendar year of our award-winning, international, bi-monthly Model 'A' News magazine.

Includes detailed technical and Era fashion articles, Model A historical articles, coverage of National Meets and Region News, classified ads, and vendor ads - a great source of information for parts and services.

From 64 to 72 pages each issue. Excellent quality coated paper with color, and black and white photography.



OUR ADVERTISERS

"ONE MILE AHEAD"
Smith and Jones
ANTIQUE AUTO PARTS
SPECIALIZING IN MODEL A AND MODEL T PARTS
60 Wisconsin St, W Columbia, SC 29170

Quality Parts • Same Day Shipping
• Established 1972 •

Order Desk 1-800-422-1928
1-803-822-4141 • Fax 1-803-822-8477
All Major Credit Cards Accepted

Davin E. Smith



Orders: www.snjparts.com
Email: snjparts@gmail.com

Bentley's

Antique Auto Service, Inc.

We are a Full Service Shop, specializing in Model A Fords

We offer Award-Winning Paint and Bodywork

Expert Service and a Complete Machine Shop

678-407-1947 www.mymodela.com

Enjoy the Drive...



803-568-5499

The Henhouse Ministry

A Non-Profit Christian Organization

Open Wednesdays
9am-3pm

PO Box 203 1556 Whetstone Rd.
Hwy #3
Swansea, SC 29160

thehenhouseministry@gmail.com

The World's Largest Selection of 1909-31 Ford Parts

Snyder's

ANTIQUE AUTO PARTS

12925 Woodworth Rd. • New Springfield, OH 44443

Toll Free Ordering (888) 262-5712

or FAX (888) 262-5713

Order On-Line @ www.snydersantiqueauto.com

FREE Fully Illustrated CATALOG
\$10.00 outside the U.S., Canada, & Mexico



"HAVE AN "A" DAY" 

Michael Butcher

1-888-879-6453

email: mike@mikes-afordable.com

www.mikes-afordable.com



Specializing in 1928 - 1931 Model A Ford Parts

Pardee's

Refrig. & Air Conditioning Inc.

* Since 1937 *

C. R. Pardee

1101 Miller Ave.
Columbia, SC 29203
(803) 779-2269

PO Box 3133
Columbia, SC 29230
Fax (803) 765-1558

TOM MACK 1-(888) TOM-MACK

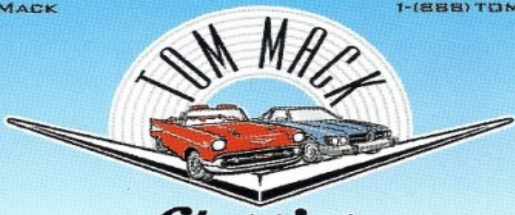

Classics

P.O. BOX 327 • PROSPERITY, SC 29127
TEL: (803) 364-3322 • FAX: (803) 364-2826
EMAIL: TMACK@TOMMACKCLASSICS.COM
WWW.TOMMACKCLASSICS.COM

Trading in Model A's since 1974.
Cell # 803-351-3695

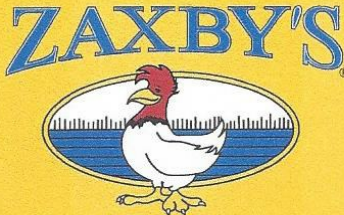

2320 Augusta Rd. • West Columbia • 803.739.1300
1759 S. Lake Dr. • Lexington • 803.996.6000
823 Hwy. 378 • Lexington • 803.785.4000

© 2015 Zaxby's Franchising, Inc. "Zaxby's" is a registered trademark of Zaxby's Franchising, Inc.

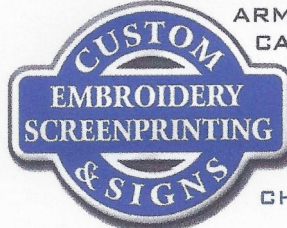

ARM BANDS ★ BACK PATCHES
CAR MAGNETS ★ BANNERS
TEES ★ POLOS
AND MUCH MORE!

CHRISTY SMITH
CHRISTY@CUSTOMEMB.NET

10525 GARNERS FERRY RD EASTOVER, SC

803-695-0403

COMPANYCASUALS.COM/CUSTOMEMB

The Palmetto A's Model A Club, of MAFCA and MARC does not endorse or in any way approve or disapprove the use of any person or enterprise that advertises in *The Spare Tire* newsletter.